

Welcome to

Electric Machines & Drives

thomasblairpe.com/EMD



Thomas Blair, P.E.

USF Polytechnic – Engineering
tom@thomasblairpe.com



**Session 5:
3 Ph Induction Mach.**

Fall 2011

Session 5

- **Chapter 13 – Three Phase Induction Machines**
- **Chapter 14 – Selection & Application of Three Phase Induction Machines**
- **Chapter 15 – Equivalent Circuit of the Induction Motor**

Chapter 13 – Three Phase Induction Machines

Example 13-6

A 3 phase, 8 pole, squirrel cage induction motor, connected to a 60 Hz line, possesses a synchronous speed of 900 rpm. The motor absorbs 40kW, and the copper and iron losses in the stator amount to 5kW and 1kW respectively. Calculate the torque developed by the motor.

Chapter 13

Typical torque speed curve of a 3 phase squirrel cage induction motor

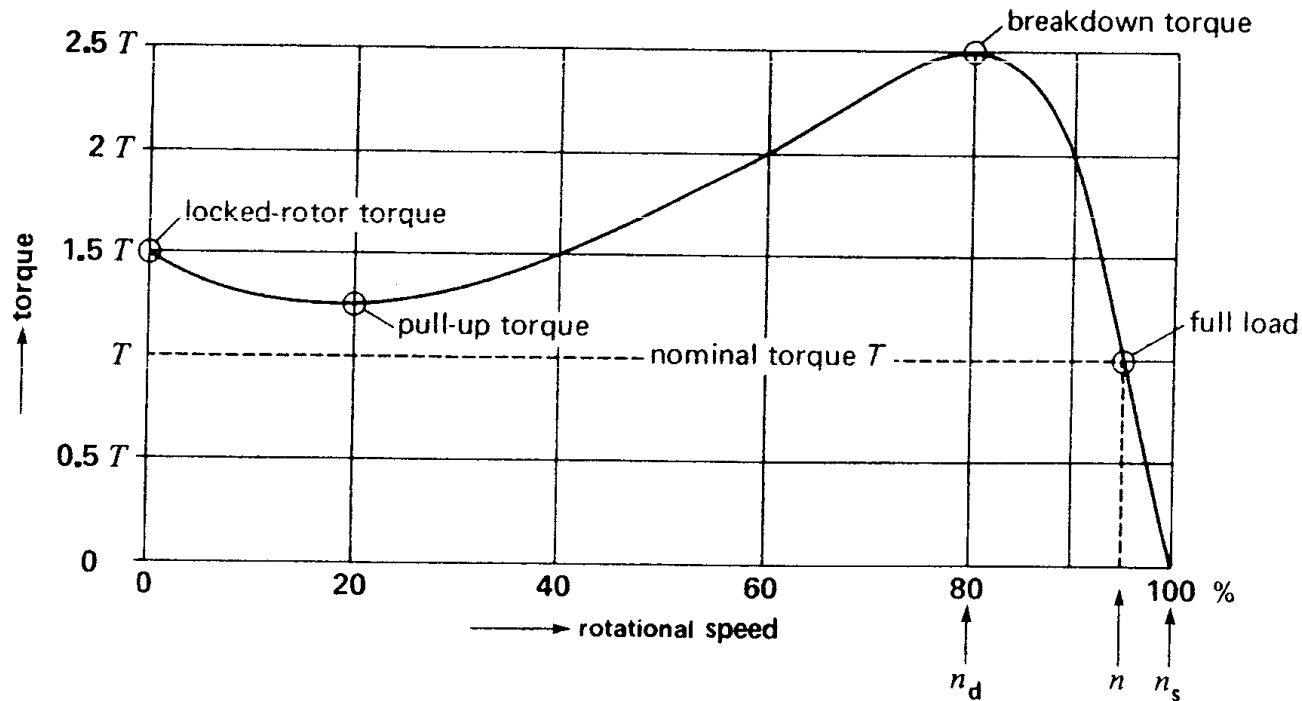

Chapter 13

Effect of rotor resistance

(a)
normal rotor
resistance = R

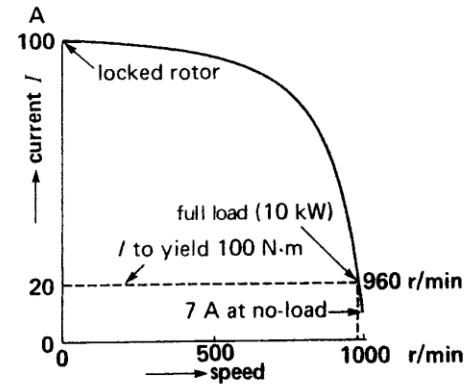
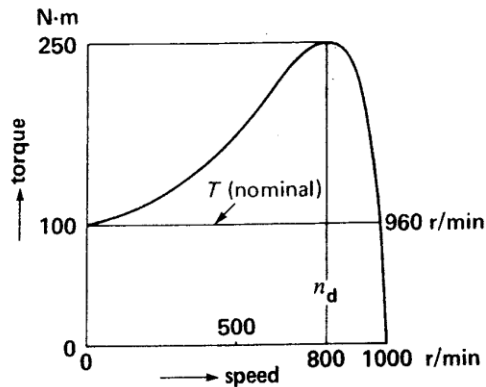

(b)
rotor
resistance = $2.5 R$

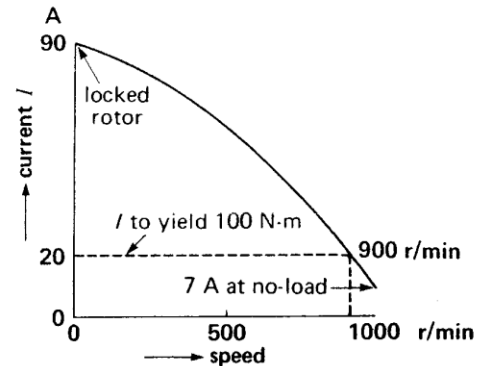
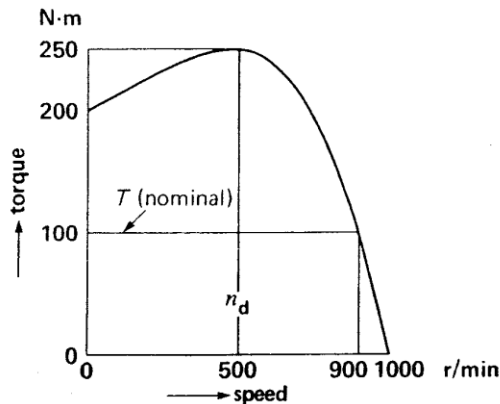

Chapter 13

Starting Torque increased, slip increased,
starting current reduced, breakdown torque
not effected (to a point)

Start -> high resistance, Run -> low resistance

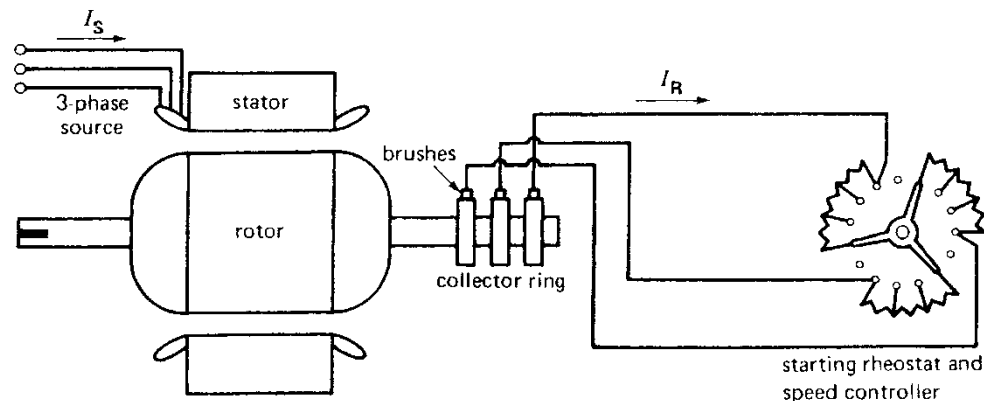

Figure 13.19

External resistors connected to the three slip-rings of a wound-rotor induction motor.

Chapter 13

Three phase winding design –

Salient pole design vs lap winding design

Phase groups = #poles X #phases (X
#windings)

Increase # of coils per group -> better starting
torque & less noise

#slots = # coils

Pole pitch = # coils / # poles

Coil Pitch = width of coil (typical 80%-100%
pole pitch)

120° electrical separation between phases

Groups = poles * phases

8

Example 13-8

The stator of a 3 phase, 10 pole induction motor possesses 120 slots. If a lap winding is used, calculate the following:

- a. The total number of coils
- b. The number of coils per phase
- c. The number of coils per group
- d. The pole pitch
- e. The coil pitch (expressed as % of the pole pitch) if the coil width extends from slot 1 to slot 11

Example 13-9

A stator having 24 slots has to be wound with a 3 phase, 4 pole winding. Determine the following;

1. The connections between the coils
2. The connections between the phases

Groups = 12, 2 coils per group, pole pitch = $24/4 = 6$ slots / pole

Chapter 13

May be wye or delta connection

Convert from measured resistance to per winding resistance -

$$R_{A1-B1} = 2 * R_{\text{winding}}$$

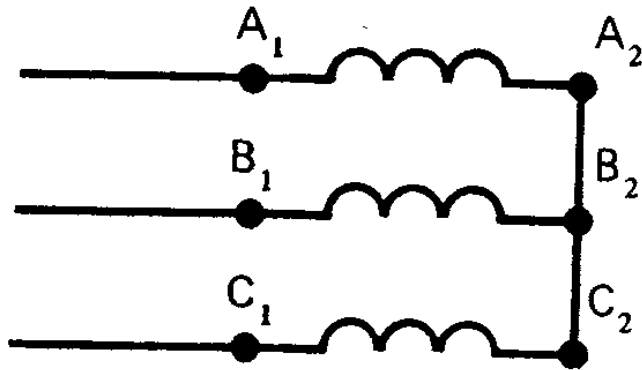

$$R_{A1-B1} = (2/3) * R_{\text{winding}}$$

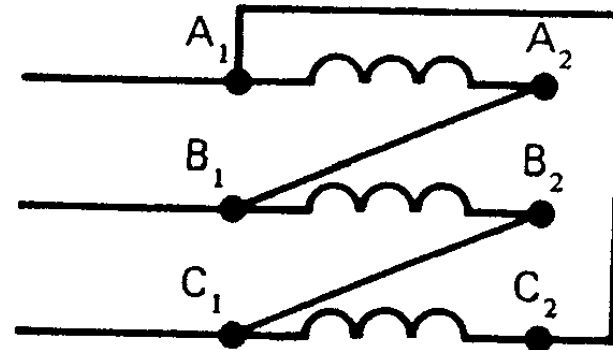

Chapter 13

Pole Pitch vs Coil Pitch

The pole pitch is from slot 1 to slot 7

The coil pitch is from slot 1 to slot 6

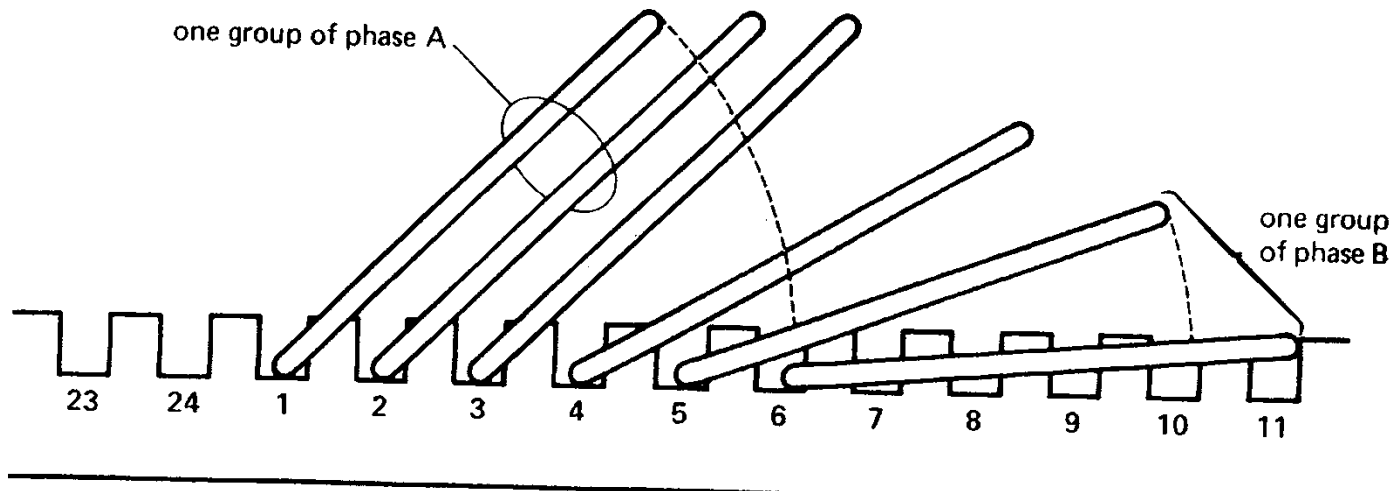

Chapter 13

Linear Induction Motor –

Linear speed – depends on frequency & pole pitch

Typically 2 stator sides to one rotor or alternately stator moving and rotor stationary

$$v_s = 2 w f$$

v_s = linear synchronous speed (m/s)

w = width of one pole pitch (m)

f = frequency (Hz)

Chapter 13

Linear Induction Motor

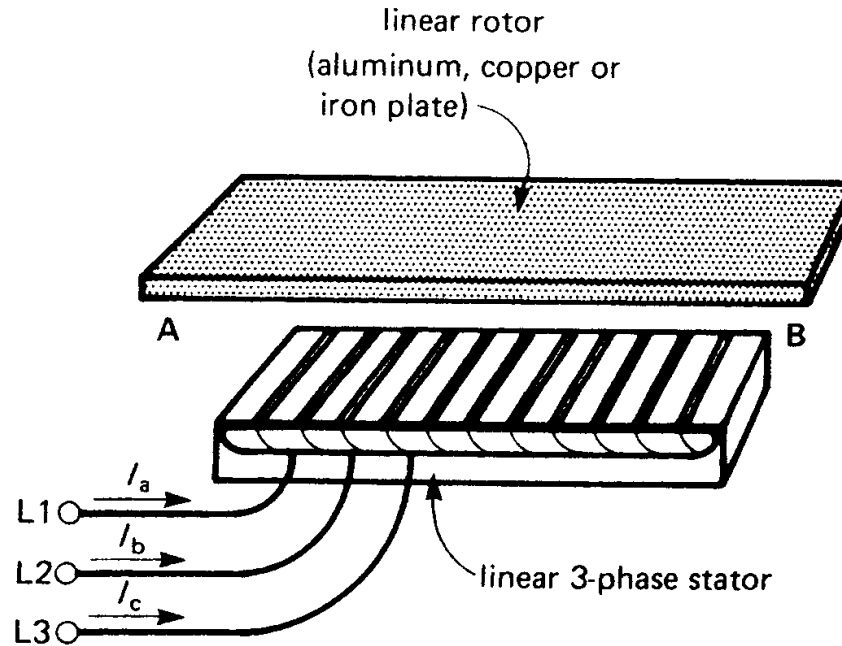

Figure 13.27

Components of a 3-phase linear induction motor.

Example 13-10

The stator of a linear induction motor is excited from a 75 Hz source. If the distance between consecutive phase groups of phase A is 300 mm, calculate the linear speed of the magnetic field.

15

Chapter 13

Linear Induction Motor Properties

$$s = (v_s - v) / v_s$$

$s = \text{slip}$

$v_s = \text{synchronous linear speed (m/s)}$

$v = \text{speed of rotor (or stator) (m/s)}$

Chapter 13

Efficiency, rotor I²R loss and mechanical power same.

$$\eta = P_i / P_e$$

$$P_{jr} = s P_r$$

$$P_m = (1 - s) P_r$$

Chapter 13

Horizontal Force (Thrust) developed based on

$$\text{Work} = F * d,$$

$$P = v * F$$

$$F = P_r / v_s$$

F = thrust (N)

P_r = power transmitted to rotor (W)

v_s = linear synchronous speed (m/s)

Example 13-11

An overhead crane in a factory is driven horizontally by means of two linear induction motors whose rotors are the two steel I beams upon which the crane rolls. The 3 phase, 4 pole linear stators have a pole pitch of 8 cm and are driven by a variable frequency source. During a test on one motor, the following results were obtained.

19

Example 13-11

Stator frequency = 15 Hz

Power to stator = 5 kW

Copper loss + iron loss in stator = 1 kW

Crane speed = 1.8 m/s

Calculate

- Synchronous speed and slip
- Power to the rotor
- I^2R loss in rotor
- Mechanical power and thrust

Chapter 13

Doubly-fed wound rotor motor

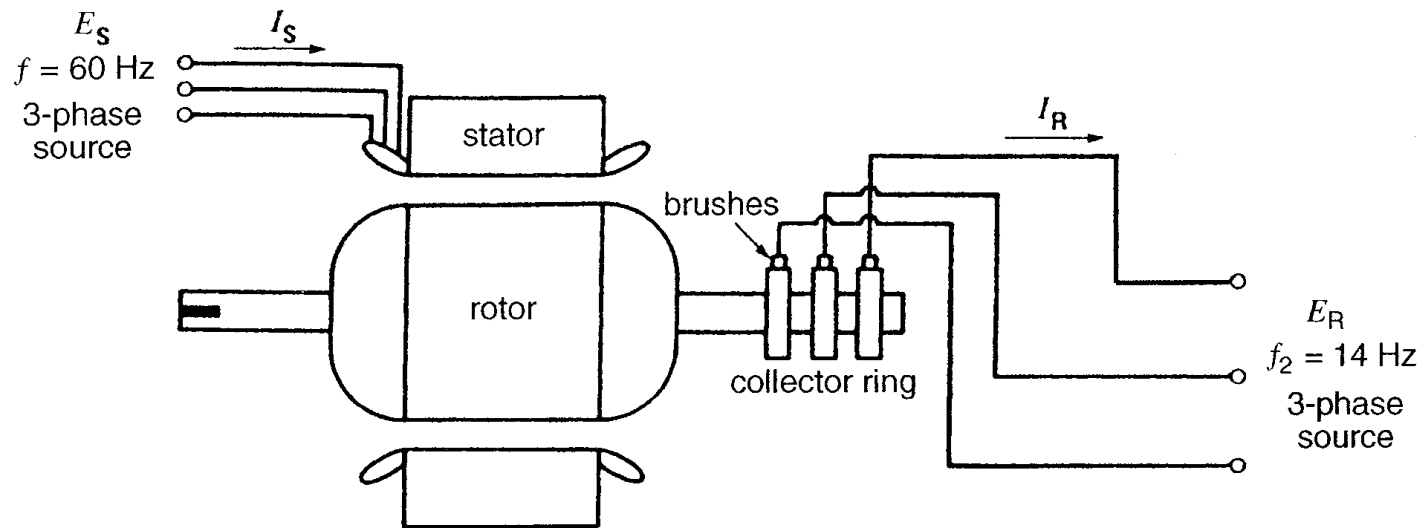

Figure 13.33

Doubly-fed wound-rotor induction motor connected to two 3-phase sources.

Chapter 13

Subsynchronous operational mode

Rotor abc – Stator abc

$$n = 120 (f_s - f_r) / p$$

n = rotor speed (rpm)

f_s = frequency applied to stator (Hz)

f_r = frequency applied to rotor (Hz)

p = number of poles

Chapter 13

Supersynchronous operational mode

Rotor abc – Stator acb

$$n = 120 (f_s + f_r) / p$$

n = rotor speed (rpm)

f_s = frequency applied to stator (Hz)

f_r = frequency applied to rotor (Hz)

p = number of poles

Subsynchronous Motor

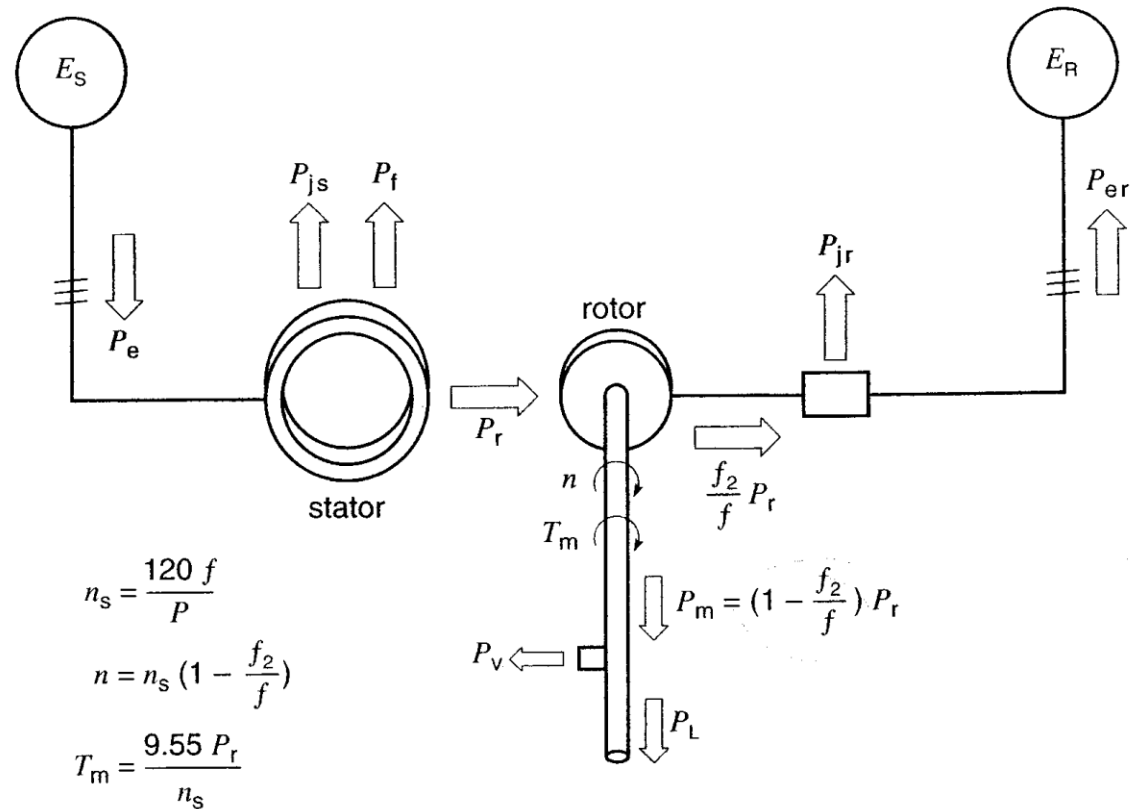

Figure 13.35

Power flow in a doubly-fed wound-rotor induction motor in subsynchronous mode.

Supersynchronous Motor

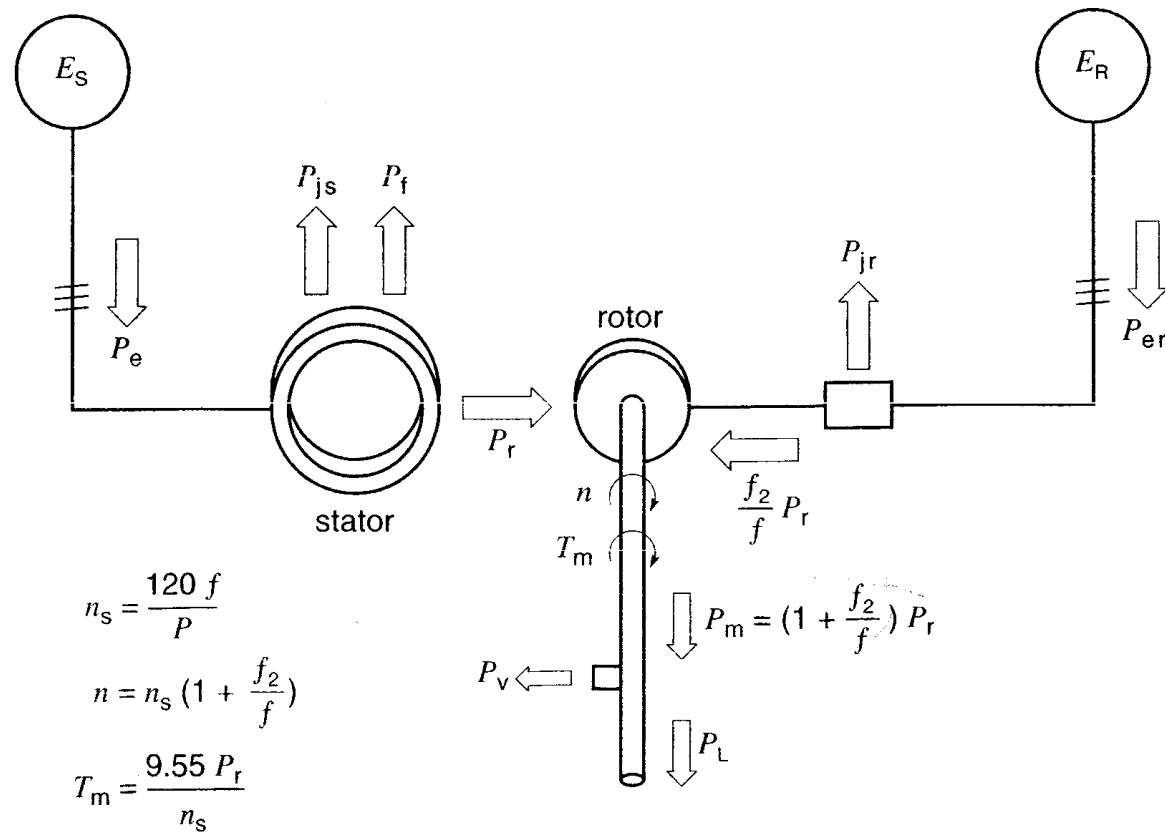

Figure 13.36

Power flow in a doubly-fed wound-rotor induction motor in supersynchronous mode.

Subsynchronous Generator

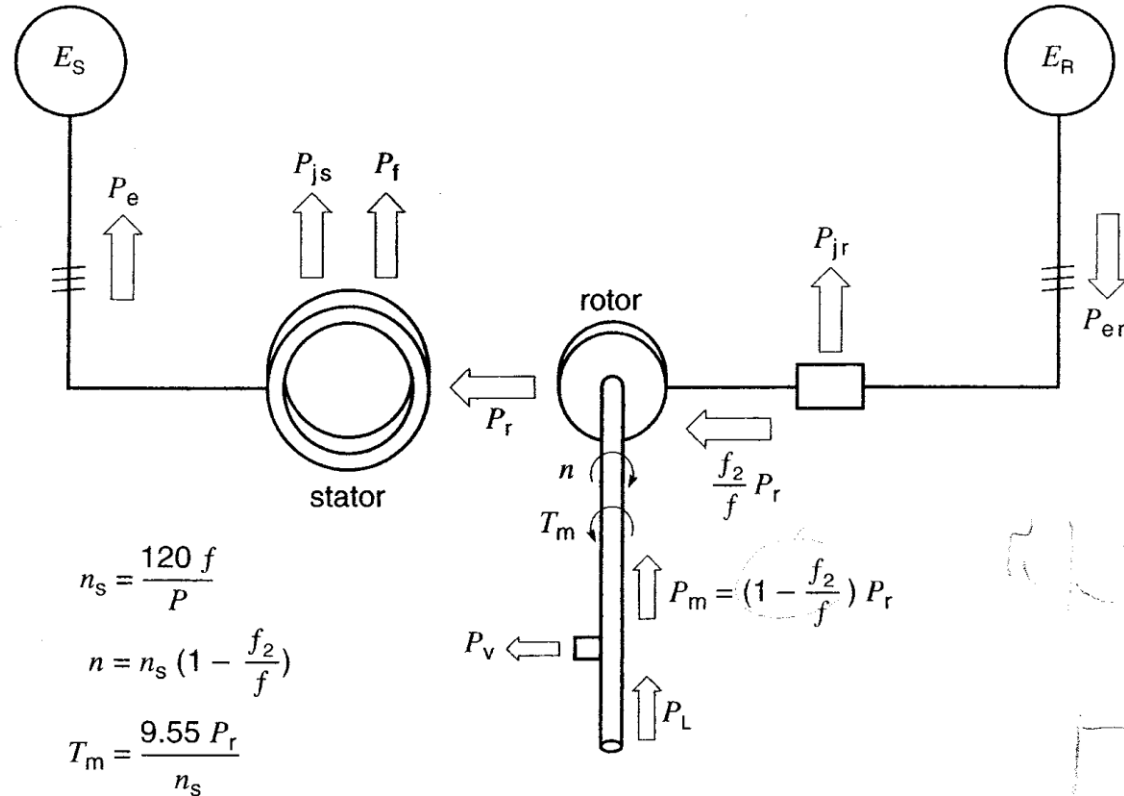

Figure 13.37

Power flow in a doubly-fed wound-rotor induction generator in subsynchronous mode.

Supersynchronous Generator

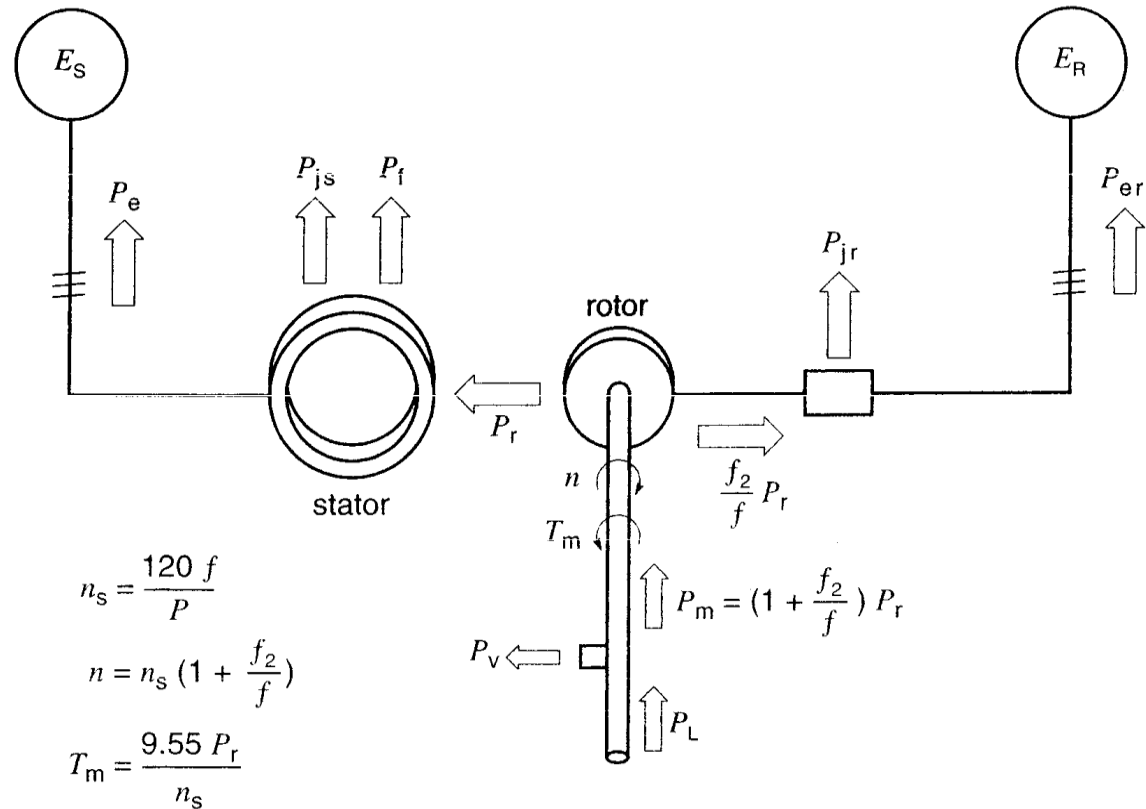

Figure 13.38

Power flow in a doubly-fed wound-rotor induction generator in supersynchronous mode.

Example 13-12

A 3 phase, 6 pole, doubly fed induction generator operating in subsynchronous speed has a rating of 800 kW. The stator is connected to a 60 Hz line and rotor is connected to a variable frequency source with frequency of 24 Hz. The machine develops 500 HP. The wind turbine is connected to the rotor shaft by a speed raising gear box.

Example 13-12

Following information applies:

Gear box / friction loss	P_v	11 kW
Rotor I ² R loss	P_{jr}	3 kW
Stator I ² R loss	P_{js}	12 kW
Stator iron loss	P_f	7 kW
Converter loss	P_c	2 kW

Example 13-12

Calculate;

- a. The subsynchronous speed of the rotor (rpm)
- b. The mechanical power P_m delivered to the rotor (kW)
- c. The electromagnetic power P_r transferred from the rotor to the stator (kW)
- d. The mechanical torque T_m at the input to the rotor (kN m)
- e. The electric power P_{er} delivered to the rotor windings (kW)
- f. The electric power P_2 absorbed by the converter from the 60 Hz power line (kW)
- g. The electric power P_e delivered by the stator to the 60 Hz power line (kW)
- h. The efficiency P_1 / P_I of the wind turbine assembly (%)

30

Chapter 14 – Selection & Application of Three Phase Induction Machines



Electric Machines and Drives
Thomas Blair, P.E.
(tom@thomasblairpe.com)

Chapter 14

NEMA design starting characteristics

Shallow bars = higher resistance

Deep bars reduced resistance

Starting – current mostly in shallow bar

Running – current shared and deep bar

resistance low

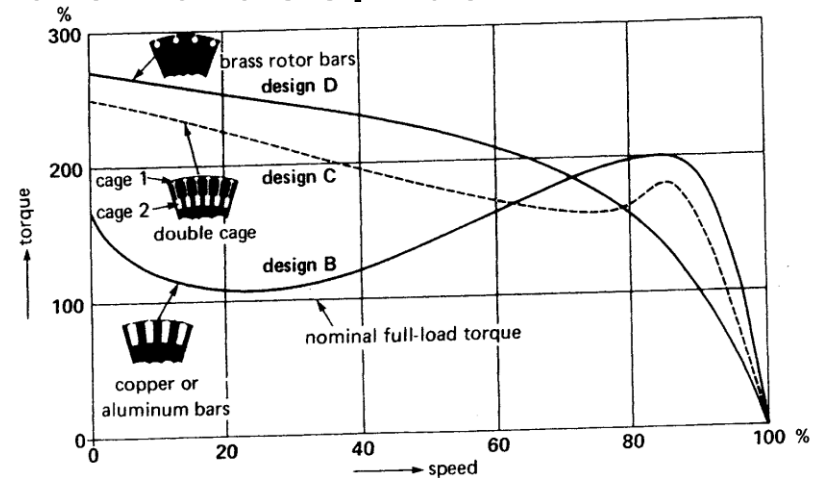

Chapter 14

Two Speed Motor designs –
Multiple windings with multiple poles
Simulated or “consequent” pole generation
Coil pitch only 50% of pole pitch.

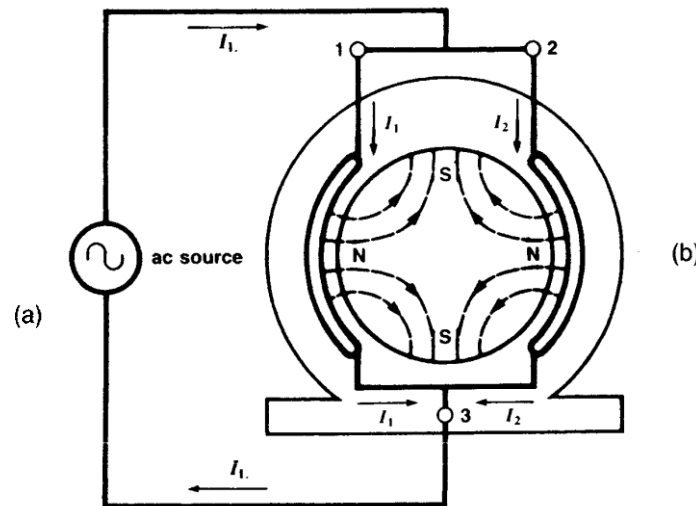
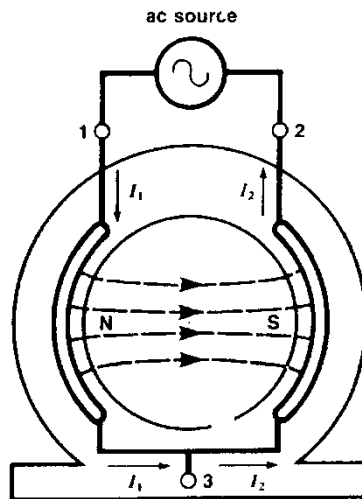

Series connection for 4 pole, 900 RPM (60hz)
 Parallel connection for 8 pole, 450 RPM (60hz)
 HS – pwr -> 1, 2, 3, LS – pwr -> 4, 5, 6 (1, 2, 3, neutral)
 Constant power / constant torque / variable torque config

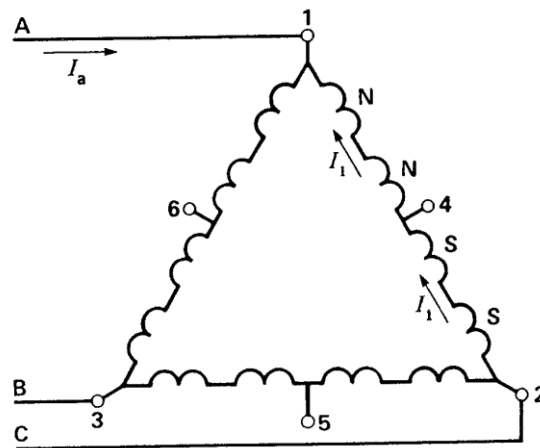

(a)

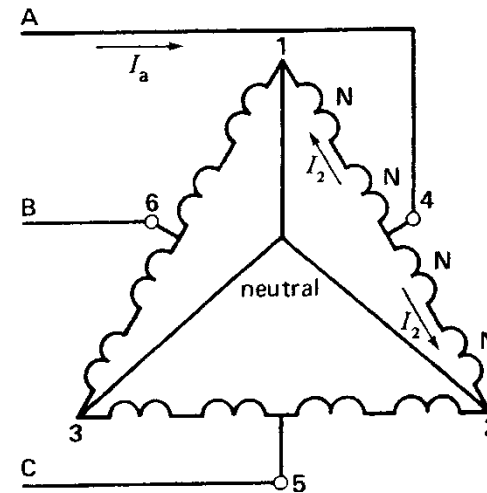

Chapter 14

Between NL and FL – torque curve linear

s = slip

T = torque

R = rotor resistance

E = stator voltage

k = constant due to rotor construction

Chapter 14

$$S = k T R / E^2$$

$$S_x = S_n [T_x/T_n] [R_x/R_n] [E_n/E_x]^2$$

n = initial load conditions

x = new load conditions

S = slip

T = torque (N m)

R = Rotor resistance (Ω)

E = Stator Voltage (V)

Example 14-1

A 3 phase, 208V induction motor having a synchronous speed of 1200 rpm runs at 1140 rpm when connected to a 215V line and driving a constant torque load. Calculate the speed if the voltage increase to 240V.

Example 14-2

A 3 phase, 8 pole induction motor driving a compressor runs at 873 rpm immediately after started from a 460V, 60 Hz line. The initial cold rotor temperature is 23°C. The speed drops to 864 rpm after the machine runs for several hours. Calculate

- The hot rotor resistance in terms of the cold resistance
- The approximate hot temperature of the rotor bars, knowing they are made of copper.

38

Example 14-3

A 3 phase, 4 pole, wound rotor induction motor has a rating of 110 kW, 1760 rpm, 2.3 kV, 60 Hz. Three external resistors of 2 Ω are connected in wye across the rotor slip rings. Under these conditions the motor develops a torque of 300 N m at a speed of 1000 rpm. Calculate

- a. The speed for a torque of 400 N m
- b. The value of the external resistors so that the motor develops 10 kW at 200 rpm.

Chapter 14

Starting an induction motor – LRA vs. FLA,
LRT, PUT, BDT, FLT

RULE 1 – The heat dissipated in the rotor during the starting period is equal to the final kinetic energy stored in all the revolving parts.

NOTE: Rule 1 true if no load on motor during start – If load on motor during accel, Heat dissipated in rotor greater than rule 1.

40

Chapter 14

Motor Plugging –

P_m – dissipated as heat & P_e – dissipated as heat. Large I^2R losses

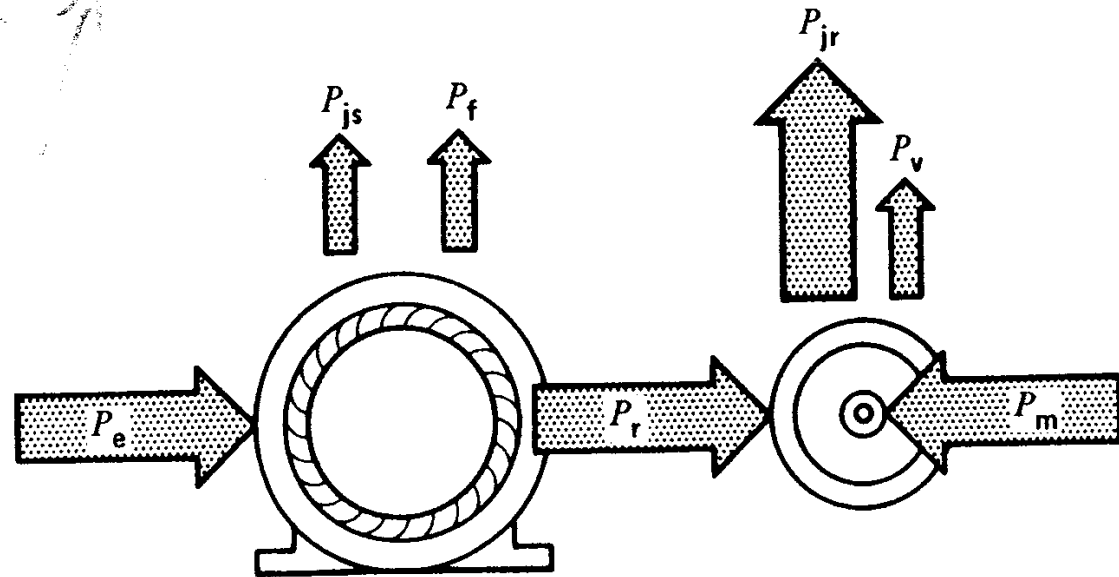

Chapter 14

Motor Plugging –

P_m – dissipated as heat & P_e – dissipated as heat

Large I^2R losses

RULE 2 – The heat dissipated in the rotor during the plugging period is **THREE** times the original KE of all revolving parts.

Example 14-4

A 100 kW, 60 Hz, 1175 rpm motor is coupled to a flywheel by means of a gearbox. The KE of all revolving parts is 300 kJ when motor runs at rated speed. The motor is plugged to a stop and allowed to run up to 1175 rpm in the reverse direction. Calculate the energy dissipated in the rotor if the flywheel is the only load.

Chapter 14

DC injection Braking –
Less heat dissipation than plugging
(proportional to load KE)
DC current magnitude \rightarrow flux strength \rightarrow
braking time

Example 14-5

A 50 hp, 1760 rpm, 440V, 3 phase induction motor drives a load having a total moment of inertia of 25 kg m^2 . The dc resistance between two stator terminals is 0.32Ω and the rated motor current is 62A. We want to stop the motor by connecting a 24V battery across the terminals. Calculate

- a. The dc current in the stator
- b. The energy dissipated in the rotor
- c. The average braking torque if the stopping time is 4 min.

45

Chapter 14

Induction Generating region –

$n > n_s$ – Torque changes direction -> power is
torque X speed -> motor is now generator
(asynchronous generator)

Power proportional Torque X Speed

VAR required from system to provide energy
for magnetic field generation

Chapter 14

Induction motor in generating mode –
Motor is active power source but still reactive
power sink

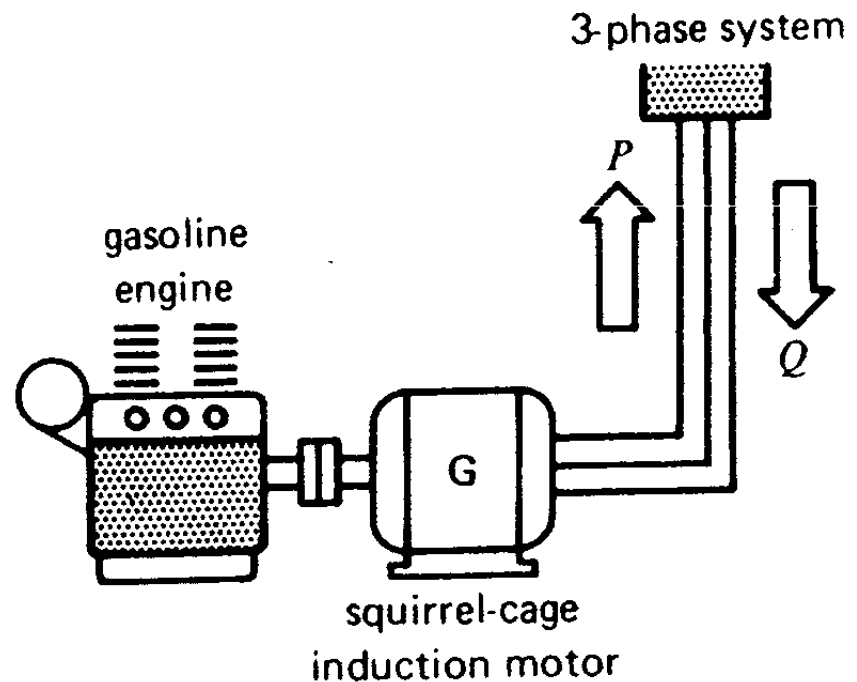

Chapter 14

Torque / speed curve of induction machine

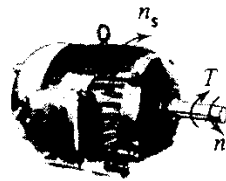
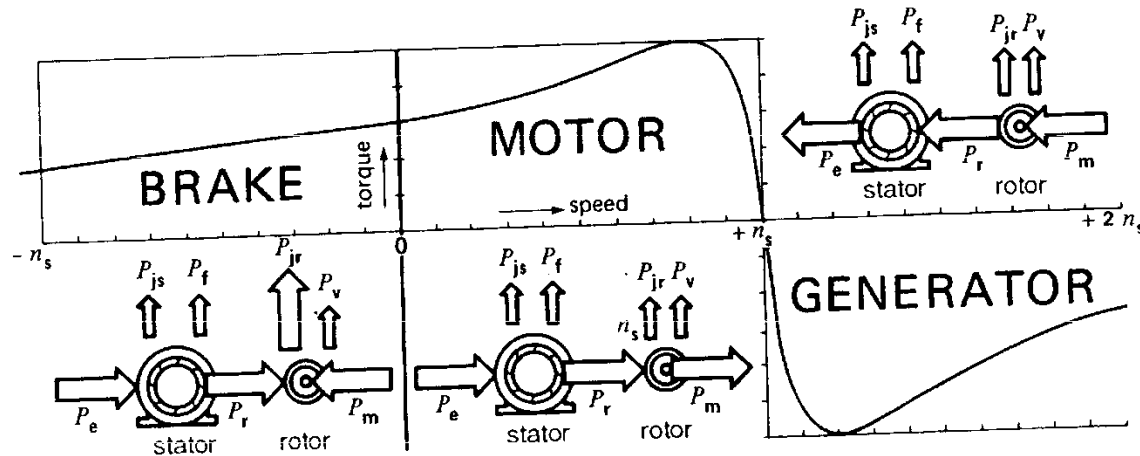

T = torque developed by the machine

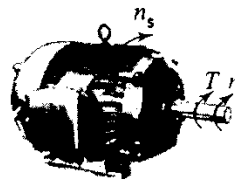

n = speed of rotation

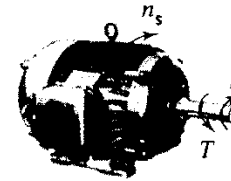

n_s = synchronous speed of the revolving field

Induction Braking, Motoring, Generating

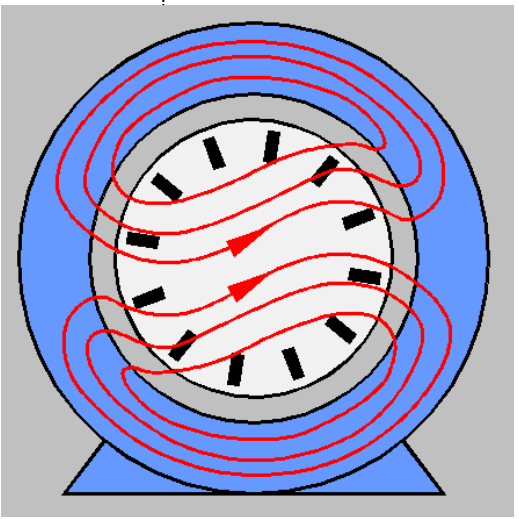
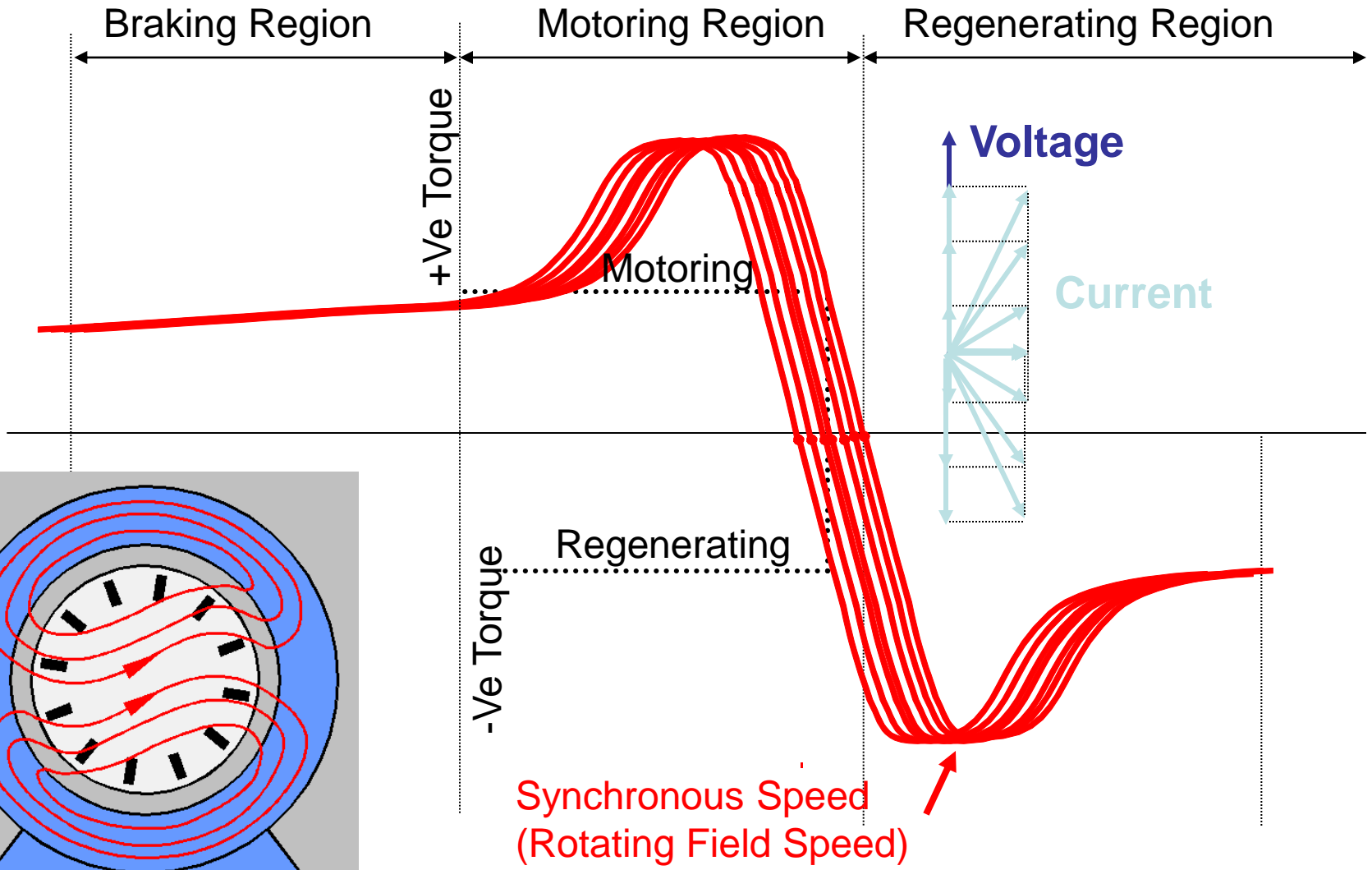

Chapter 14

Wound Rotor Motor –

1. Startup of high inertia loads
 - a. Heat in external resistor – not rotor
 - b. Vary external resistor – alter torque/speed curve
2. Variable speed drive – converter on rotor circuit
 - a. Inefficient – heat lost in external resistor
3. Frequency converter – (increased freq by counter rotation)
 - a. Improved efficiency – no external resistor bank loss

50

Chapter 14

Frequency Converter application – wound rotor motor

Frequency desired > utility frequency -> braking region

Rotor circuit frequency & voltage are:

$$f_2 = s f_s$$

$$E_2 = s E_{oc}$$

Example 14-7

A 3 phase, wound rotor induction motor has a rating of 150 hp (110 kW), 1760 rpm, 2.3 kV, 60 Hz. Under locked rotor conditions, the open circuit rotor voltage between the slip rings is 500V. The rotor is driven by a variable speed dc motor. Calculate

- a. The turn ratio of the stator to rotor windings
- b. The rotor voltage and frequency when the rotor is driven at 720 rpm in the same direction as the revolving field.
- c. The rotor voltage and frequency when the rotor is driven at 720 rpm in the opposite direction of the revolving field.

Chapter 15 – Equivalent Circuit of the Induction Motor

Chapter 15

Similar to Transformer – circuit similar

Wye connection – 1:1 transformer

Motor magnetizing component NOT negligible

2HP, shift magnetizing circuit to source side

Frequency in rotor circuit = $s \cdot f$

Chapter 15

Active Power – (Independent of magnetizing ckt)

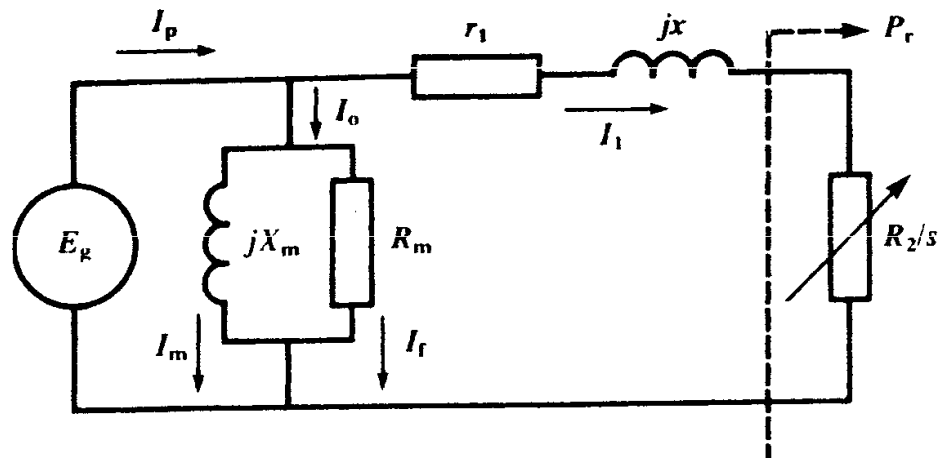

1. Active Power absorbed by motor is

$$P = E_g^2/R_m + I_1^2 r_1 + I_1^2 R_2/s$$

NOTE CORRECTION TO TEXT BOOK

Chapter 15

Reactive Power –

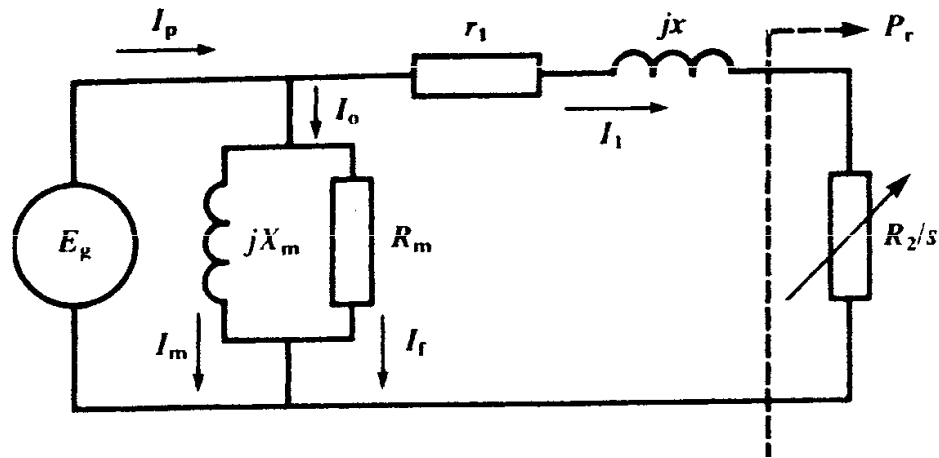

2. Reactive Power absorbed by motor is

$$Q = E_g^2/X_m + I_1^2 x$$

Chapter 15

Apparent Power –

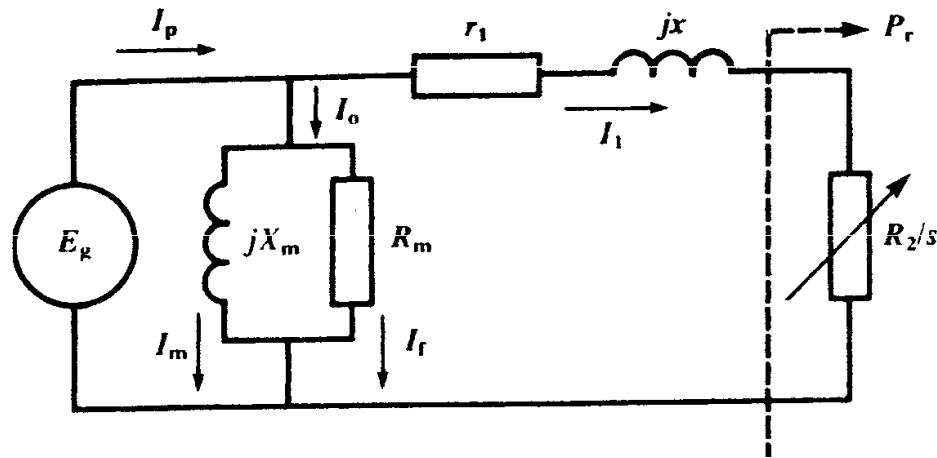

3. Apparent Power

4. PF

$$S = \sqrt{P^2 + Q^2}$$

$$PF = \cos \Theta = P/S$$

Chapter 15

Line Current –

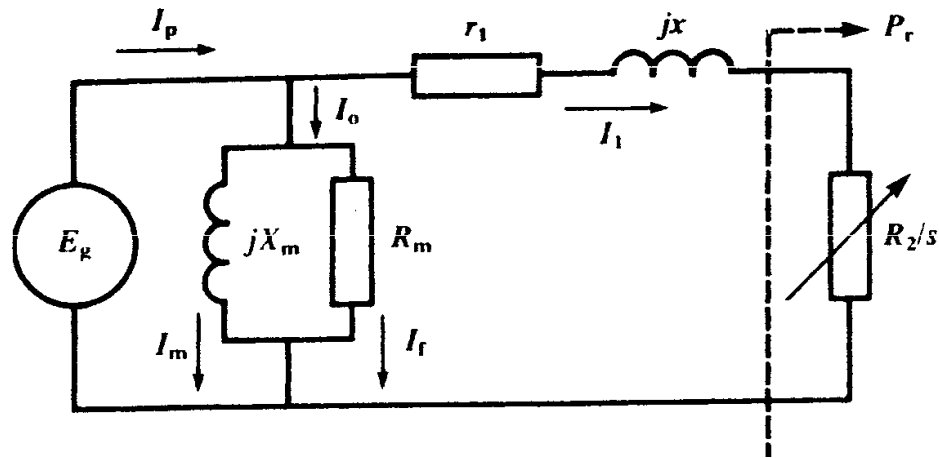

5. Line current

$$I_p = S / E_g$$

Chapter 15

Real power to the rotor –

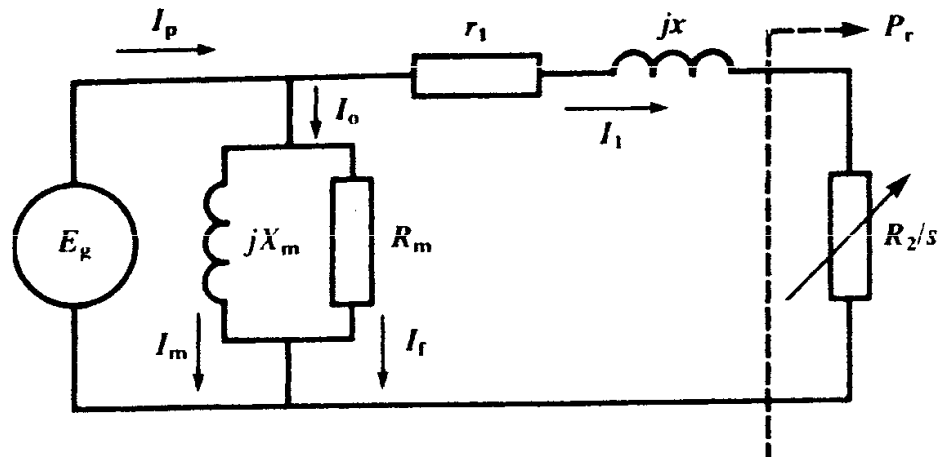

6. Active Power to the rotor

$$P_r = I_1^2 R_2 / s$$

Chapter 15

Rotor I^2R losses –

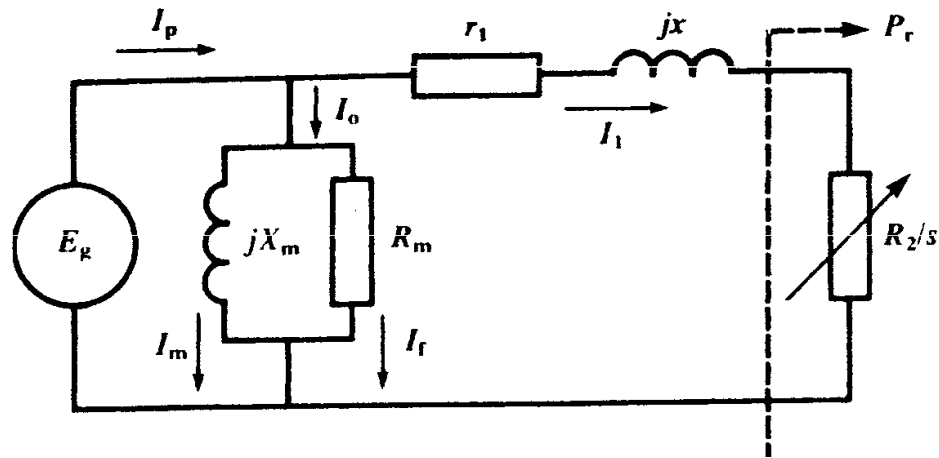

7. Rotor I^2R losses

$$P_{jr} = I_1^2 R_2 = s P_r$$

Chapter 15

Mechanical Power (Shaft Power) -

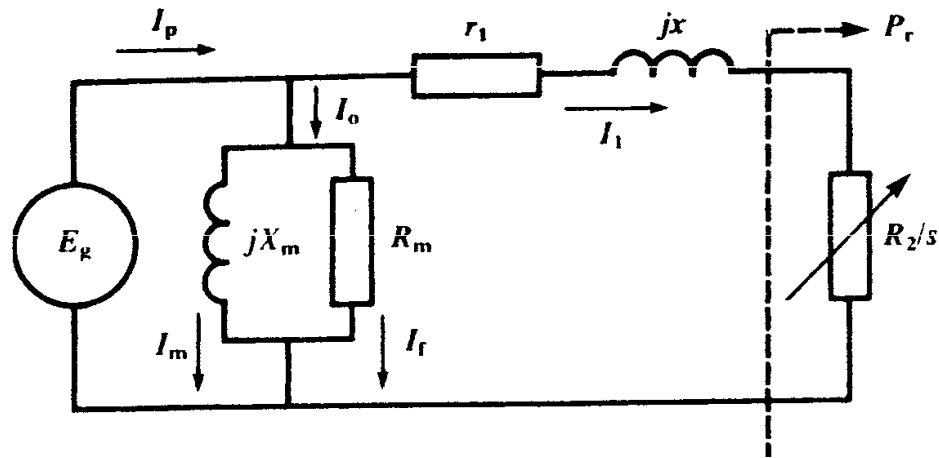

8. Mechanical power is

$$P_m = P_r - P_{jr} = P_r (1-s)$$

Chapter 15

Torque -

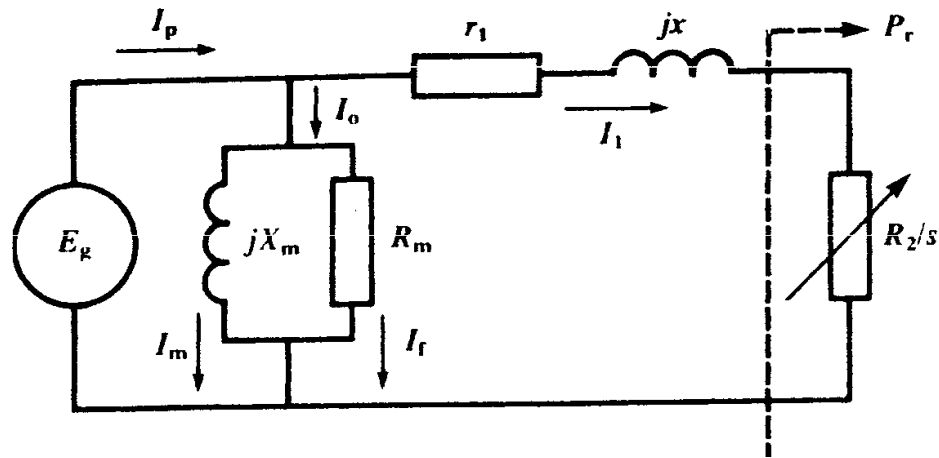

9. Torque developed by motor is

$$T = 9.55 P_m / n = 9.55 P_r / ns$$

Chapter 15

Torque -

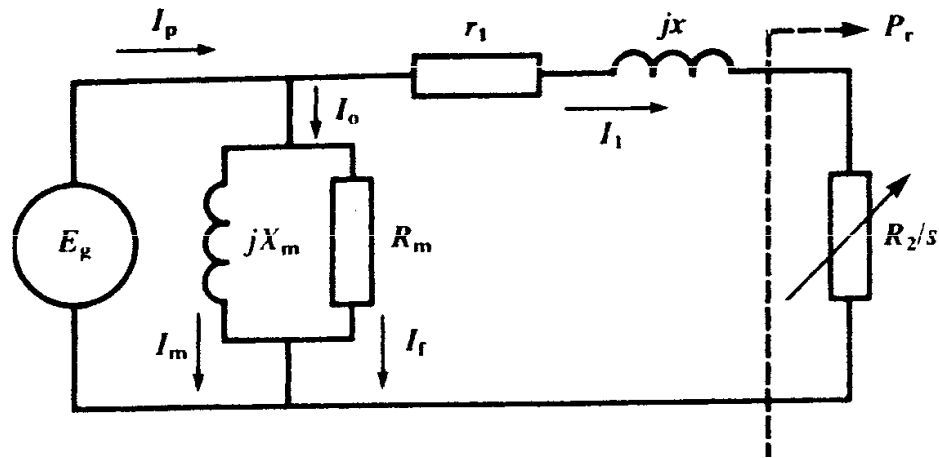

10. Efficiency of motor is

$$\eta = P_m / P$$

Chapter 15

Simplified circuit for P, T, and speed
Ignore X_m and R_m

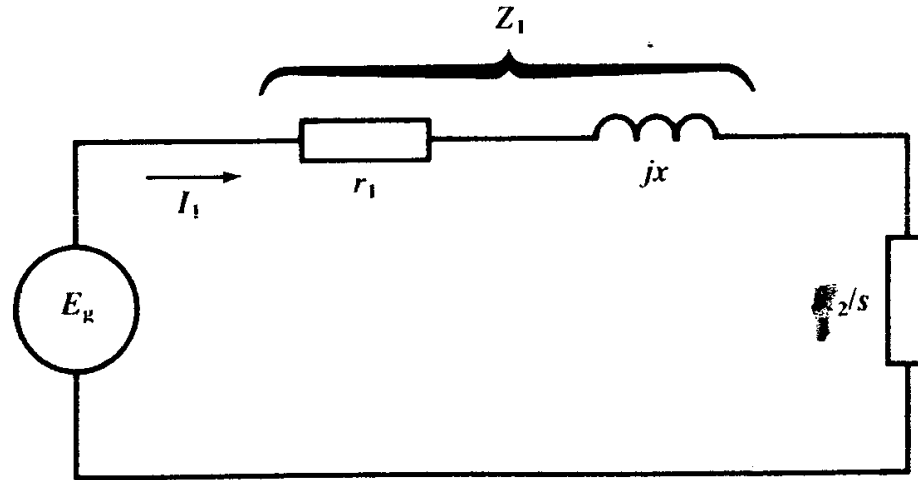

$$Z_1 = \sqrt{r_1^2 + x^2}$$

$$\alpha = \arctan(x/r_1)$$

Chapter 15

Torque max (breakdown) when: $Z_1 = R_2/s$

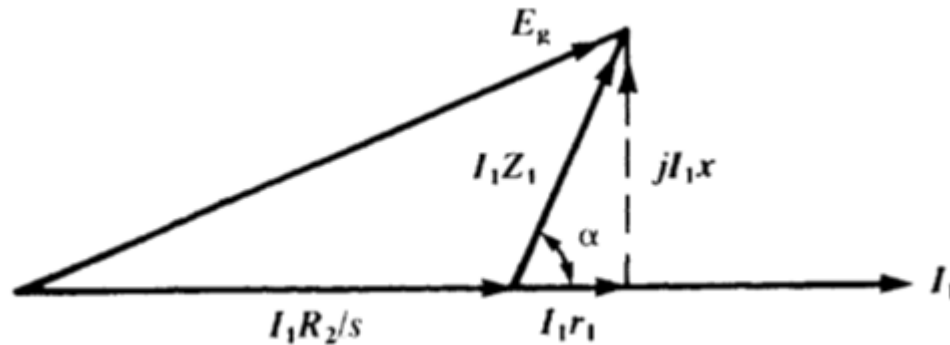
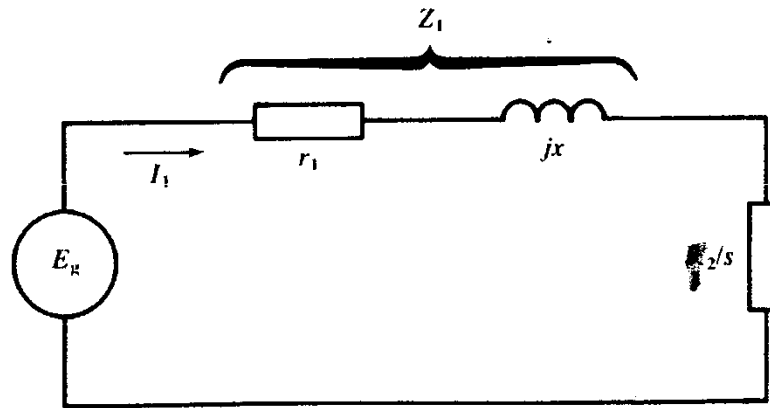

Chapter 15

Breakdown Torque (max value of torque, max value E_g)

Torque max (breakdown) when: $Z_1 = R_2 / s$

$$S_b = R_2 / Z_1$$

$$I_{1b} = E_g / (2 Z_1 \cos \alpha/2)$$

$$T_b = 9.55 E_g^2 / [ns(4 Z_1 \cos^2 a/2)]$$

Chapter 15

$$S_b = R_2 / Z_1$$

$$I_{1b} = E_g / (2 Z_1 \cos \alpha/2)$$

$$T_b = 9.55 E_g^2 / [ns(4 Z_1 \cos^2 \alpha/2)]$$

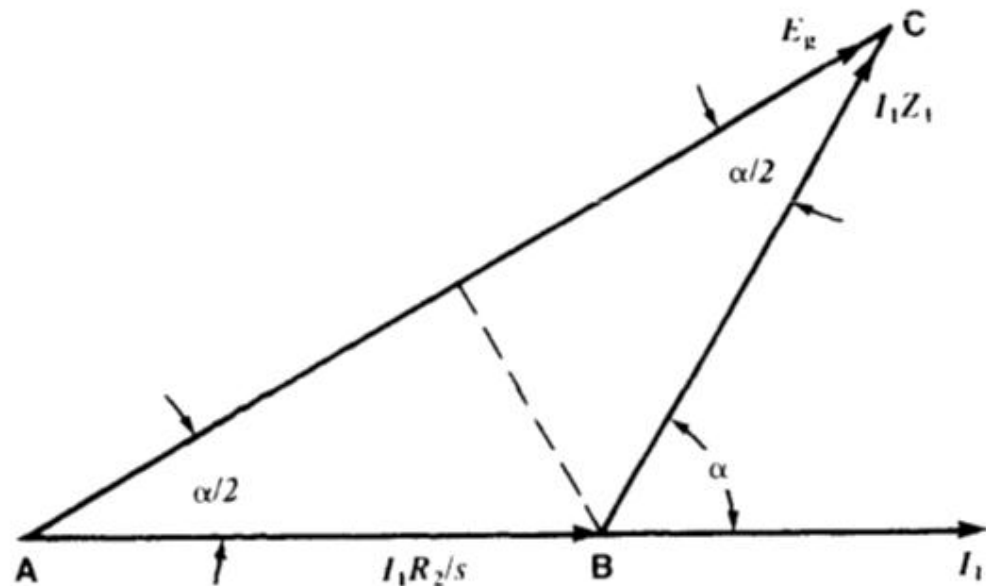

Chapter 15

No Load Test Arrangement

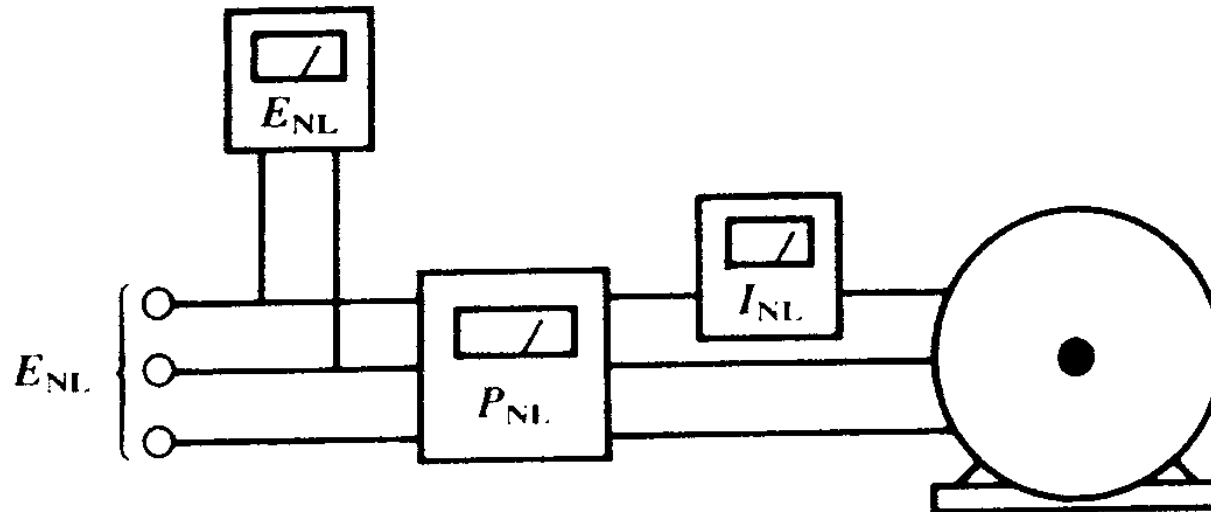

Figure 15.17

A no-load test permits the calculation of X_m and R_m of the magnetizing branch.

Chapter 15

No Load Test determines magnetizing circuit.

I_1 is small compared to I_o

Only magnetizing branch applies

- a. Measure the stator resistance R_{ll} between any two terminals. Assuming wye connection, $r_1 = R_{ll} / 2$
- b. Run motor at no load using rated line to line voltage, E_{nl} . Measure no load current I_{nl} and 3 phase active power P_{nl} .

Following calculations apply:

69

Chapter 15

Power calculations are

$$S_{nl} = E_{nl} I_{nl} \sqrt{3}$$

$$Q_{nl} = \sqrt{(S_{nl}^2 - P_{nl}^2)}$$

Winding, Friction, and iron loss ($P_f + P_v$) are

$$(P_f + P_v) = P_{nl} - 3 I_{nl}^2 r_1$$

Magnetizing resistance R_m & reactance X_m are

$$R_m = E_{nl}^2 / (P_f + P_v)$$

$$X_m = E_{nl}^2 / Q_{nl}$$

Chapter 15

Locked Rotor Test Arrangement

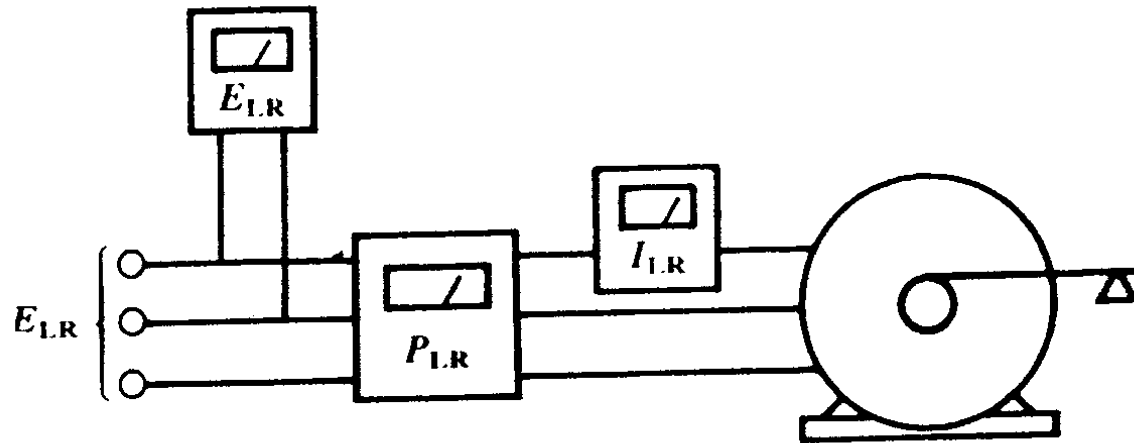

Figure 15.18

A locked-rotor test permits the calculation of the total leakage reactance x and the total resistance $(r_1 + r_2)$. From these results we can determine the equivalent circuit of the induction motor.

Chapter 15

Locked Rotor – reduced voltage

- a. Apply reduced 3 phase voltage to the stator so that the stator current is about equal to its rated value
- b. Take readings of E_{lr} (line to line), I_{lr} , and the 3 phase active power P_{lr} .

Following calculations apply:

72

Chapter 15

Power calculations are

$$S_{lr} = E_{lr} I_{lr} \sqrt{3}$$

$$Q_{lr} = \sqrt{S_{lr}^2 - P_{lr}^2}$$

$$R_2 = P_{lr} / (3 I_{lr}^2) - r_1$$

$$X = Q_{lr} / (3 I_{lr}^2)$$

$$P_{lr} = 3 I_{lr}^2 (r_1 + r_2)$$

Example 15-1

A no load test conducted on a 30 hp, 835 rpm, 440V, 3 phase, 60 Hz, squirrel cage induction motor yielded the following results

No load voltage (L-L)	440V
No load current	14A
No load power	1470W
Resistance R_{ll}	0.5 ohm

Example 15-1

The locked rotor test, conducted at reduced voltage, gave the following results

Locked rotor volts	163V
Locked rotor power	7200W
Locked rotor current	60A

Determine the equivalent circuit of the motor.

75

Chapters 16 and 17 next session

Electric Machines & Drives

thomasblairpe.com/EMD



Thomas Blair, P.E.

USF Polytechnic – Engineering
tom@thomasblairpe.com



**End of Session 5:
3 Ph Induction Mach.**

Spring 2011